

IFE Tritium Collection, and Purification System

¹C. Priniski, ¹C. A. Gentile, ²J. Sethian, ¹W. Blanchard, ¹L. Ciebiera, ¹F. Dahlgren, ¹G. Gettelfinger, ¹S. Langish

¹ Princeton Plasma Physics Laboratory ² Naval Research Laboratory

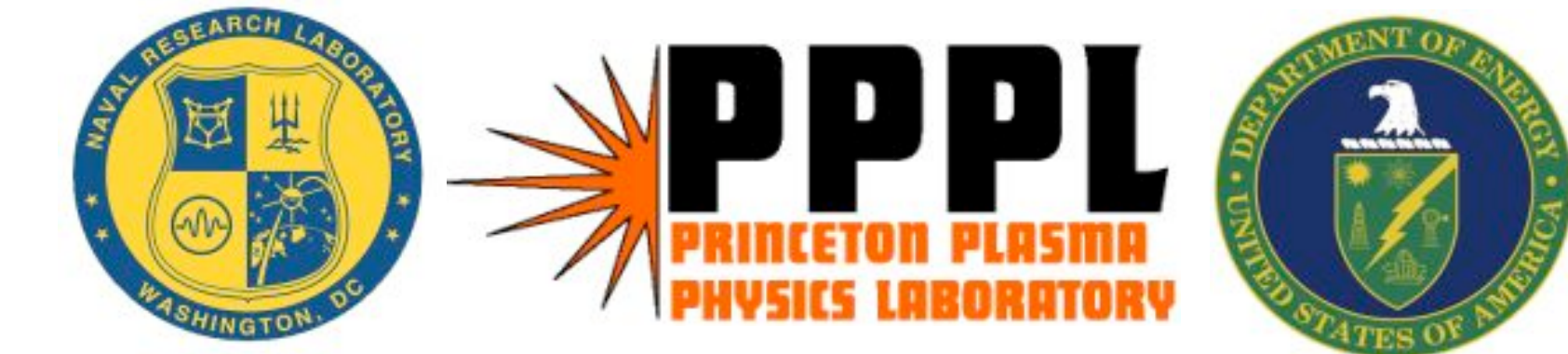

Abstract

In support of The High Average Power Laser (HAPL) Program, the Princeton Plasma Physics Laboratory is Developing an effective tritium management strategy including Conceptual Design (CD) for a tritium collection, tritium processing, and tritium purification system for the IFE target chamber plasma exhaust and blankets. For the purpose of developing an efficient system and strategy of operation(s) for the management of tritium in support of IFE target chamber (D-T operations) a Conceptual Design (CD) for a tritium system will be prepared. The CD will identify process components, process flow rates, process efficiencies (DF's) . The system will be designed as to "close" the fusion fuel cycle at the site, thus reducing the quantities of tritium required from off-site facilities post system commissioning and startup. It is expected that up to ~10 Kg of T / y could pass through the IFE target chamber in full operation. It is imperative that residual tritium remaining after each shot (as much as 70 % of the initial target quantity) be recovered and recycled for continued (additional) use. In addition tritium generated from the surrounding blankets must be collected and introduced into the fuel cycle. The system will nominally be designed for a ~ 25 Kg of T / y processing throughput. The IFE tritium system will build upon the currently proposed IFE target chamber vacuum pumping system and tritium breeding blanket parameters. The emphasis will be on providing a safe, reliable, and efficient fuel recovery system. In addition a strategy of operation will be developed by which at risk tritium for operations will be minimized in an effort to lower the level of regulatory categorization of the facility.

The proposed system will incorporate, to the fullest extent possible, commercial off the shelf (COTS) components to provide value in a cost effective fashion. Tritium compatible sub-components will be employed and ample material control accounting devices will be included in the system to accurately secure tritium inventory (process) determinations. The proposed system will include state of the art process controls (cpu) for the efficient operation of the plant.

Estimated Tritium Handling Requirements

500 kJ Target Case	Per shot		During 5 Hz full operation	
	Grams	Percent	Per Day (10 hrs)	Per Year (60%)
Targets*			Grams	Kg
Mass D-T Fuel (pre-burn)	0.00050	67.7%	90	20
Mass CH Foam (DVB)	0.00014	19.5%	26	6
Mass CH Coat (PVP)	0.00009	12.8%	17	4
Exhaust*				
Mass D-T Fuel (unburned)	0.00033	47.3%	60	13
Mass He (ash)	0.00013	18.8%	24	5
Mass CH products	0.00024	33.9%	43	9
Blanket Output				
Mass Tritium			51	9

*Trace amounts of other chemicals (Au,Pd,O2,H2O, etc.) present

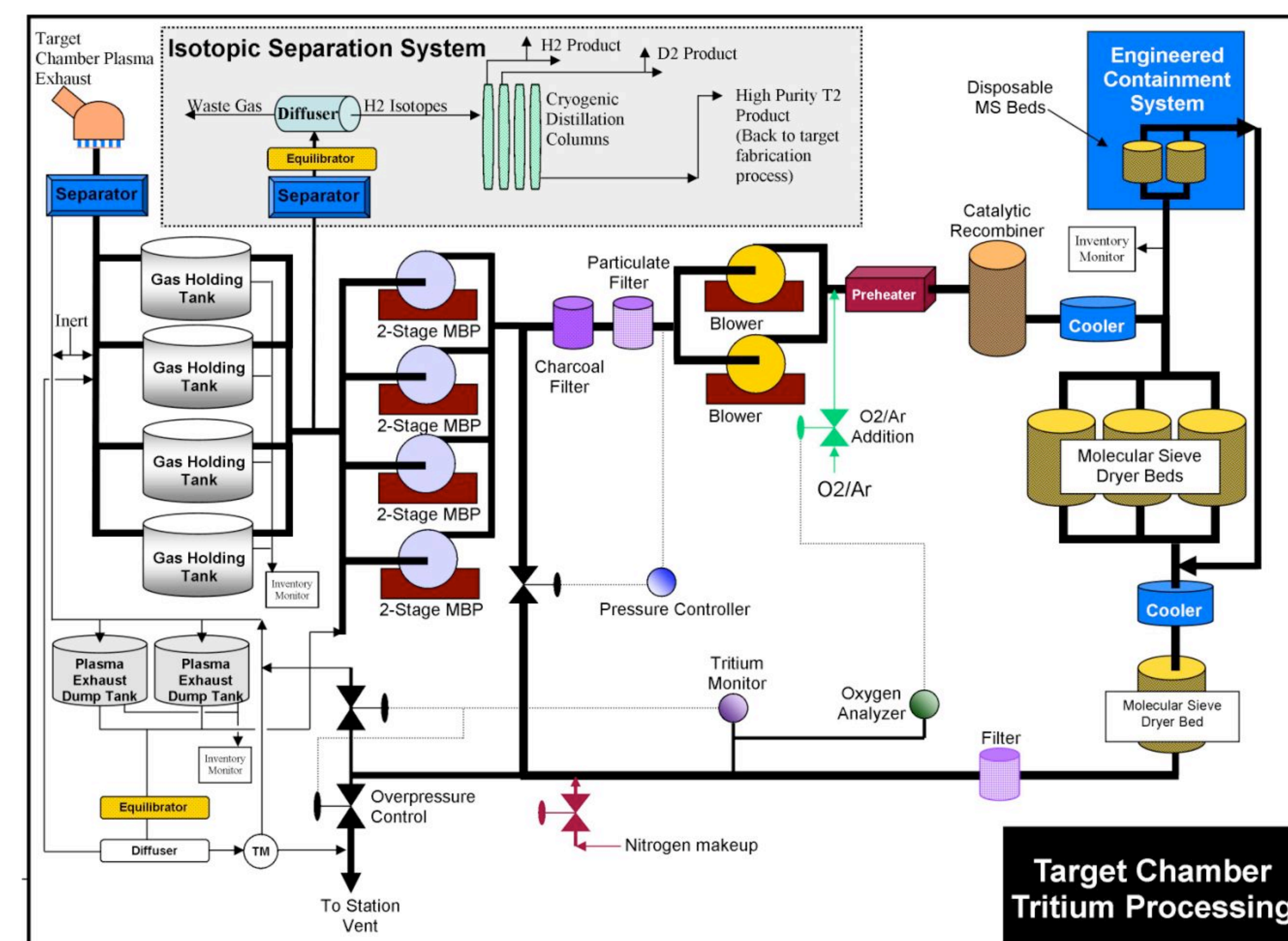
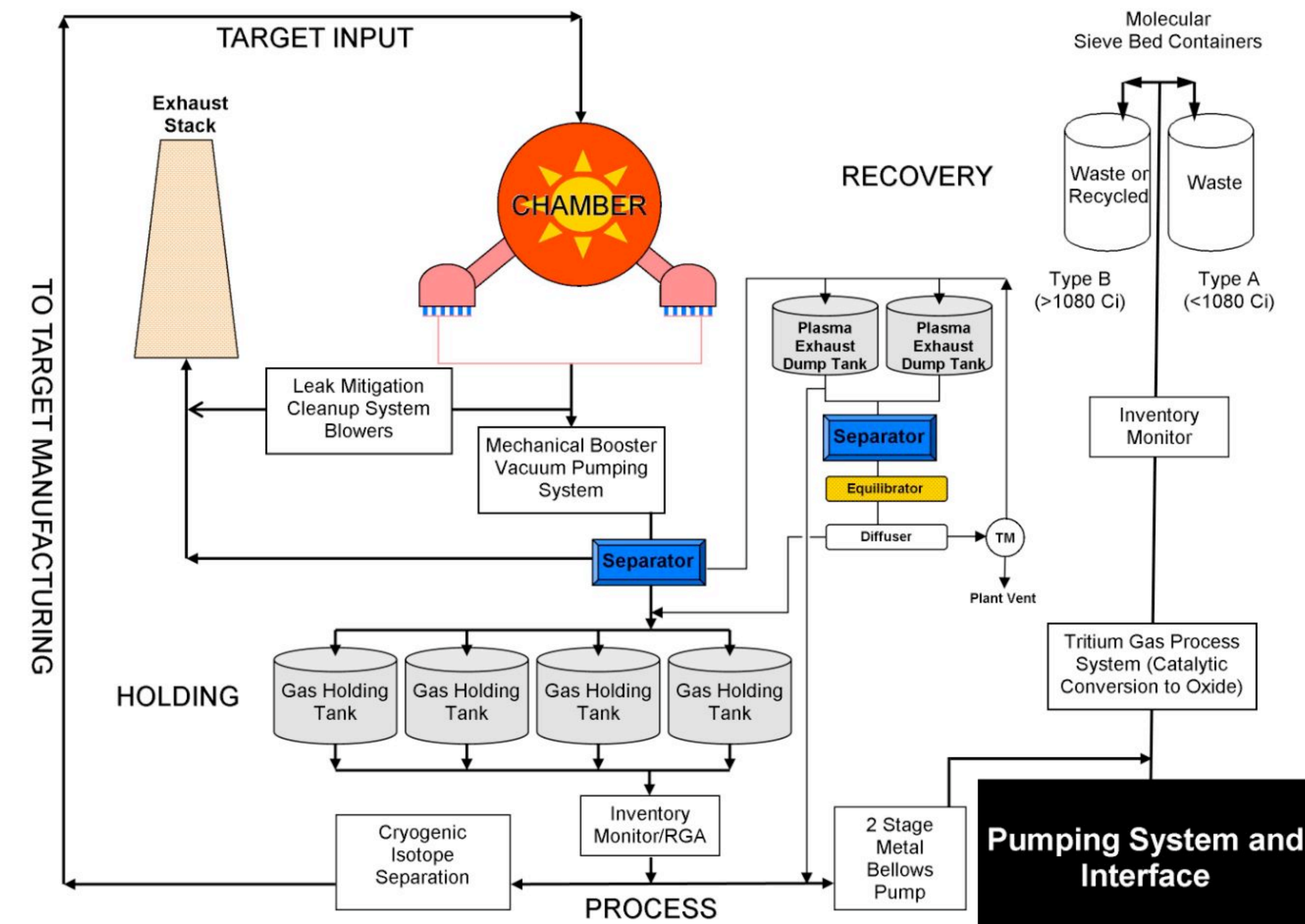

Path Forward

- Safety a primary focus everything flows from this position
- Analyze system flows to ensure a safe and efficient design
- Develop an accurate tritium accounting system
- Model system flows to identify and prevent bottlenecks in system
- Work with other sub-system groups (blanket, target fabrication) to ensure the processing system integrates readily into overall project
- Provide a viable Conceptual Design Review of System
- Investigate regulatory characterization strategy

Conclusion

- To date the fusion fuel cycle has been successfully modeled at various laboratories throughout the world.
- Two facilities have successfully processed plasma exhaust and closed the fusion fuel cycle in situ.
- The experience from modeled and empirical venues will be integrated into the CDR
- A strategy driven ramp up plan for T usage will be developed to minimize the effects of regulatory compliance and cost